

HATCH

60 & 75 WATT "R" SERIES ELECTRONIC TRANSFORMERS



Plastic Case
Models

RS12-60 AND RS12-75

RS

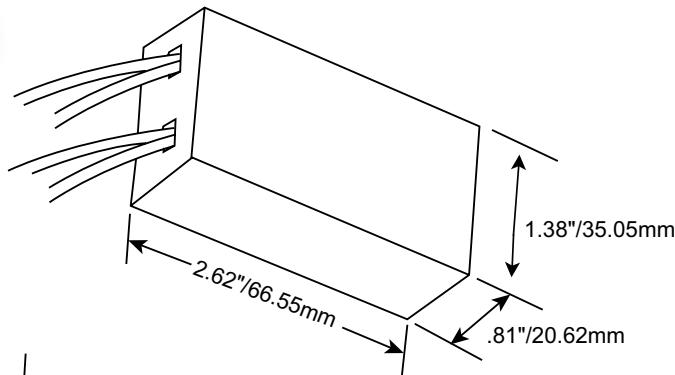

1 . Side Lead

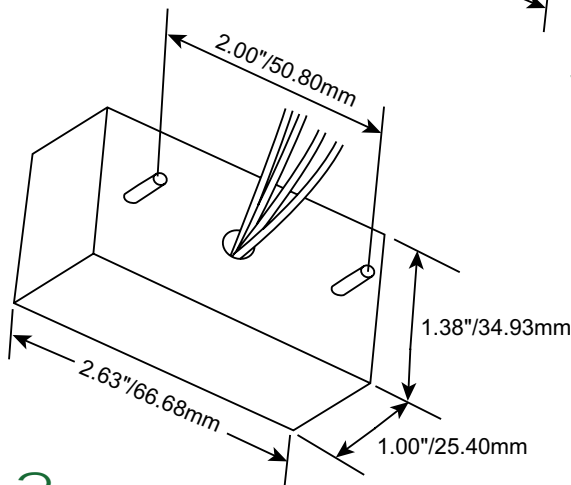

2 . Bottom Feed

Electronic Low Voltage Transformer Product Features:

- High Reliability
- Moisture Resistant
- Emits No Audible Noise
- Low Harmonic Distortion
- High Power Factor
- Lightweight, Compact Design
- Small Case Size
- Works with most commercially available dimmers. Hardwire electronic dimmers are recommended for optimum performance

Environmental Specifications

Maximum Case Temperature	80°C
Sound Rating	A+
Operating Humidity	95% relative humidity, non-condensating
Environmental Protection	Epoxy Sealed for moisture resistance and shock vibration resistance

Electrical/Mechanical Specifications

Input120 or 277 50/60 Hz
Enclosure Material Flame retardant, high temperature engineering resin
ColorBlack
Weight4 oz.
Power Factor> 0.95
Operating Frequency25 KHz
Total Harmonic Distortion≤ 20%
Safety Standard (Class 2-up to 60 Watt only)

NOTE: Bottom Feed Units are UL Listed

Input Leads6", 18AWG stranded, 105 degree C stripped 3/8" tinned
Output Leads6", 18AWG stranded, 105 degree C stripped 3/8" tinned

Soft Start Circuitry

All models of Hatch low-voltage transformers utilize a soft start circuitry to maximize lamp life. The soft start circuit ramps up the lamp filament voltage slowly when the lamp is cold.

Electronic Short-Circuit Protection

All Hatch low-voltage transformers employ our (ESP) Electronic Short Circuit and over load Protection. The ESP sensing circuit will instantly shut down the output before any of the components are stressed if a short circuit or over load is detected. The transformer will automatically reset as soon as the fault is corrected.

NOTE: UL approved high temperature 3M double sided tape available for use with side lead models only for mounting transformer to enclosure.



RS12-60 AND RS12-75 "R" SERIES

H A R D W I R E E L E C T R O N I C

Max Watts	Min Watts	Input Volts	Output Volts	Input Amps	Output Amps	Case Style	Hatch Item No.	Safety Listing
60	10	120	11.5	0.52	5.2	1	RS12-60P	UL/C-UL Recognized, Class 2
						2	RS12-60BFP	
75	10	120	11.5	0.67	6.25	1	RS12-75P	UL/C-UL Recognized
		277		0.29		2	RS12-75BFP	

*Must use a minimum of 20 watts when using dimmers.

*Note: RS12-75BF and RS12-75-277BF are UL listed.

WIRING DIAGRAMS

